

MOTION & CONTROL™

NSK

POCKET GUIDE

LINEAR MOTION



Content

Linear Guides	6
Linear Ball Guides	8
LH-Series	12
LS-Series.....	14
S1-Series.....	16
LW-Series	18
LH/LS Rails with bottom-tapped mounting holes	20
Slider optional components	21
Miniature PU&PE-Series	22
Translide TS-Series.....	26
Linear Roller Guides	28
RA-Series.....	29
Linear Guides Accessories	30
NSK K1® Lubrication System	30
Mounting tolerances	32
Linear Guides reference system	33

Monocarrier	36
Standard MCM Type.....	38
High rigidity MCH Type.....	38
Ball Screws	42
R-BS – Rolled Ball Screw Series.....	44
CFA – Ground Ball Screw Compact FA Series	46
FSS – Ground Ball Screw FSS Series	48
DS – Ground Ball Screw DS Series.....	50
WBK – Support Units.....	58
Megatorque Motors	62
PS-Series	68
PN-Series	74
Solidcomponents – NSK CAD-Data at Internet	82

About NSK

As one of the world's leading manufacturers of rolling bearings, linear technology components and steering systems, we can be found on almost every continent – with production facilities, sales offices and technology centres – because our customers appreciate short decision-making channels, prompt deliveries and local service.



The NSK company

NSK commenced operations as the first Japanese manufacturer of rolling bearings back in 1916. Ever since, we have been continuously expanding and improving not only our product portfolio but also our range of services for various industrial sectors. In this context, we develop technologies in the fields of rolling bearings, linear systems, components for the automotive industry and mechatronic systems. Our research and production facilities

in Europe, Americas and Asia are linked together in a global technology network. Here we concentrate not only on the development of new technologies, but also on the continuous optimisation of quality – at every process stage.

Among other things, our research activities include product design, simulation applications using a variety of analytical systems and the development of different steels and lubricants for rolling bearings.

Linear Guides

Linear Ball Guides

- › LH series
- › LS series
- › S1 series
- › LW wide series
- › Miniature PU/PE series
- › Translide

Linear Roller Guides

- › RA series



Linear Ball Guides

Technical features

Groove types

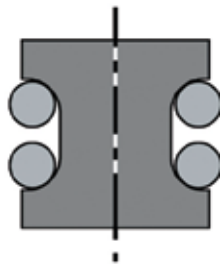

Circular groove

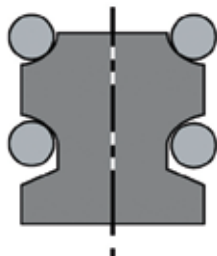

Gothic-arch groove

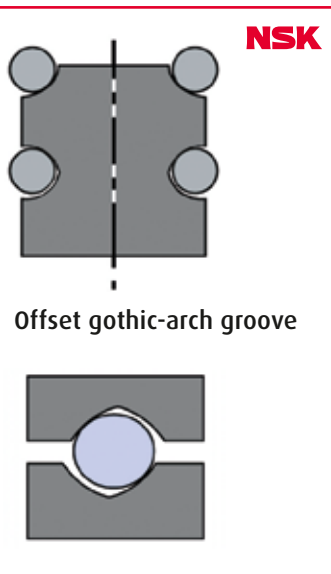

Offset gothic-arch groove

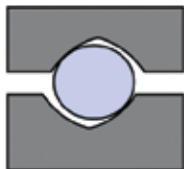
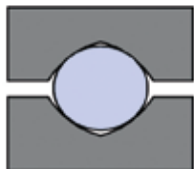
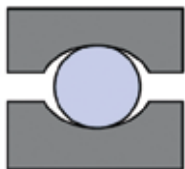

Normal load

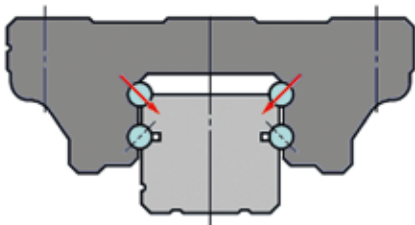

Impact load

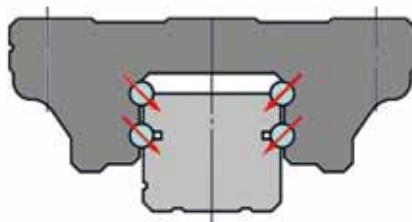

Thanks to the ball groove configuration and to the offset gothic-arch groove, the bottom rows will help carry loads when a large impact load is applied vertically, increasing the number of contact points and static load capacity.

Technical features

Contact angle configuration

NSK

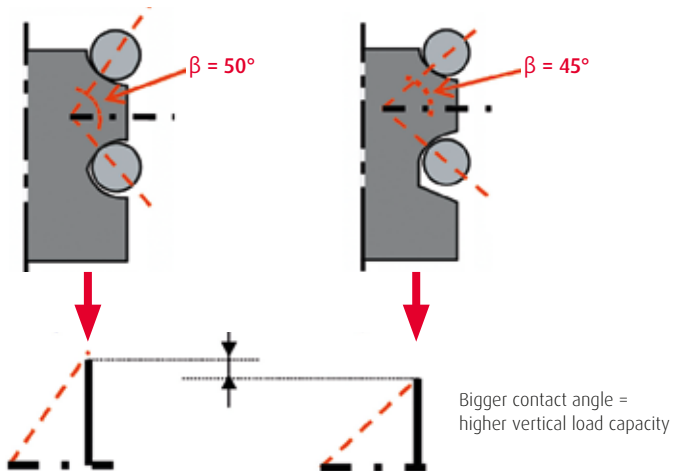

NSK

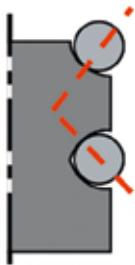

DF configuration (X)

- › Contact angle “crosses” inside the rail.
- › High self-aligning capability
- › High rigidity by parallel installed rails

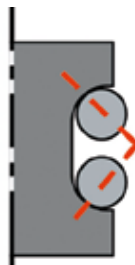

DB configuration (O)

- › Contact angle “crosses” outside the rail.
- › High stiffness in monorail applications
- › High accuracy machinable is necessary

LH | Standard-Series

- › Sizes: 15, 20, 25, 30, 35, 45, 55, 65 (on order: 8, 10, 12)
- › Slider types: AN, AL, BN, BL, EM, GM
- › Preload: Z, H
- › Options: slider with or without NSK K1® mounted, steel protector and double seal
- › Available in Martensitic stainless steel (sizes 15 - 30) or anti-corrosion Fluoride Raydent Plated treatment (sizes 15 - 65)
- › Option: Mounting caps covering the drill holes or bottom mounting hole rails

**Contact angle: 50°
DF configuration (X)**

Size	Maximum single rail length [mm]	Mounting bolt metric	Distance between mounting holes [mm]
15	1,980	M4	60
20	3,960	M5	60
25	3,960	M6	60
30	4,000	M8	80
35	4,000	M8	80
45	3,990	M10	105
55	3,960	M12	120
65	3,900	M16	150

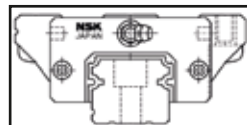
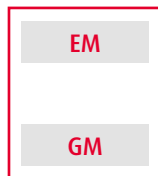
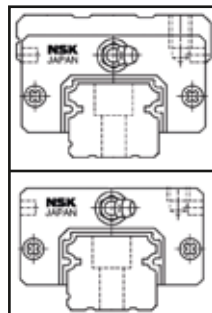
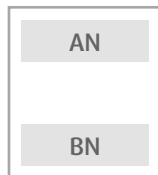
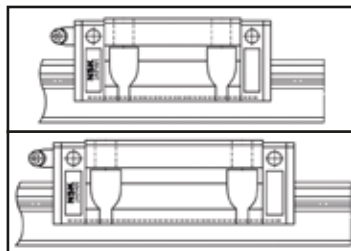
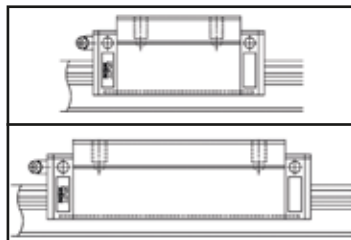

LS | Standard-Series

- › Sizes: 15, 20, 25, 30, 35
- › Slider types: CL, AL, JM, EM
- › Preload: Z, H
- › Options: slider with or without NSK K1® mounted, steel protector and double seal
- › Available in Martensitic stainless steel or anticorrosion Fluoride Raydent Plated treatment
- › Option: Mounting caps covering the drill holes or bottom mounting hole rails

**Contact angle: 50°
DF configuration (X)**

Size	Maximum single rail length [mm]	Mounting bolt metric	Distance between mounting holes [mm]
15	1,980	M3 / M4	60
20	3,960	M5	60
25	3,960	M6	60
30	4,000	M6	80
35	4,000	M8	80

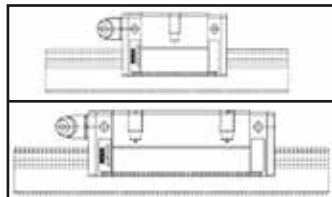

CL

AL

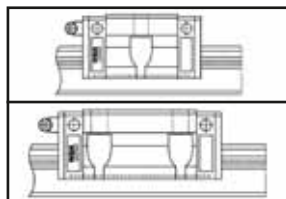
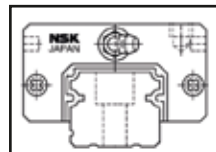

JM

EM

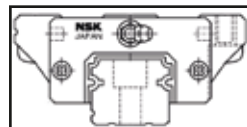

S1™ | Ball Spacers Series



S1™ Ball Spacers

NSK S1™ includes individual ball spacers made of resin, preventing ball contact and so friction between balls.

Availability:

- › SH (LH + S1™) Series (size 15–55)
- › SS (LS + S1™) Series (size 15–35)

For all slider types. Also available in several accuracy and preload types, including the interchangeable grade

- › Noise reduction of 5dB(A)
- › Vibration reduction
- › Smooth movement
- › Low dust generation
- › No dimensional changes
- › Speed up to 240m/min

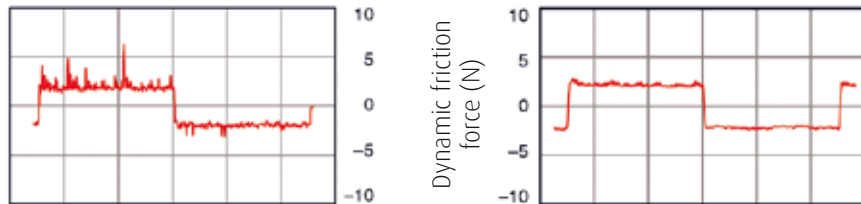

In constantly moving sliders, variations in acceleration are due to friction decreases. As a result, NSK S1™ is suitable for applications where smoothness is needed at low speed.

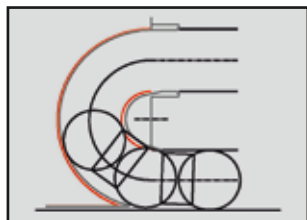

The S1™ endcap has been redesigned to allow improved recirculation of the spacers.

LW | Standard-Series

- › Sizes 17, 21, 27, 35, 50
- › 1 slider type: EL
- › 1 preload type: Z
- › Options: slider with or without NSK K1® mounted, steel protector, double seal
- › Available in anti-corrosion Fluoride Raydent Plated treatment
- › Option: Mounting caps covering the drill holes.

**Contact angle: 50°
DF configuration (X)**

Size	Maximum single rail length [mm]	Mounting bolt metric	Distance between mounting holes [mm]
17	1,000	M4	40
21	1,600	M4	50
27	2,000	M4	60
35	2,400	M6	80
50	3,000	M8	80

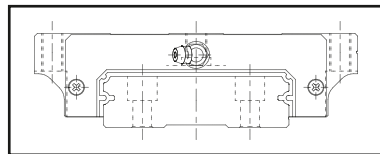
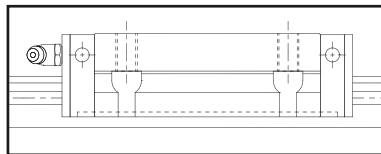

Rails with bottom-tapped mounting holes



LH/LS-Rails

Reference number	Maximum single rail length [mm]	Mounting holes metric	Material
L1H151980LVNG01PCZ	1,980	M5 x 0.80	Standard Steel
L1H203960LVNG01PCZ	3,960	M6 x 1.00	
L1H253960LVNG01PCZ	3,960		
L1H304000LVNG01PCZ	4,000	M8 x 1.25	
L1H354000LVNG01PCZ	4,000		
L1H453990LVNG01PCZ	3,990		
L1H553960LVNG01PCZ	3,960	M14 x 2.00	
L1H653900LVNG01PCZ	3,900	M16 x 2.00	
L1H253960LVNG01PCZ	3,960	M6 x 1.00	
L1S151660LVNG01PCZ	1,660	M5 x 0.80	Standard Steel
L1S203960LVNG01PCZ	3,960	M6 x 1.00	
L1S253960LVNG01PCZ	3,960	M6 x 1.00	
L1S304000LVNG01PCZ	4,000	M8 x 1.25	
L1S354000LVNG01PCZ	4,000	M8 x 1.25	

- › Double seal: Extra-sealing capability
- › Steel protector: Protect slider against solid dust particles

Easy Assembling

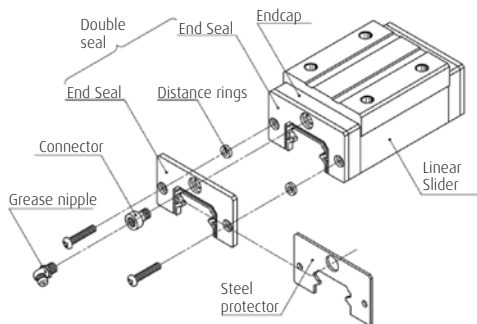

Slider optional components

Model nr.	Double seal set		Steel protector set	
	No connector*	With connector*	No connector*	With connector*
LH 15	LH15WS-01	–	LH15PT-01	–
LH 20	LH20WS-01	LH20WSC-01	LH20PT-01	LH20PTC-01
LH 25	LH25WS-01	LH25WSC-01	LH25PT-01	LH25PTC-01
LH 30	LH30WS-01	LH30WSC-01	LH30PT-01	LH30PTC-01
LH 35	LH35WS-01	LH35WSC-01	LH35PT-01	LH35PTC-01
LH 45	LH45WS-01	LH45WSC-01	LH45PT-01	LH45PTC-01
LH 55	LH55WS-01	LH55WSC-01	LH55PT-01	LH55PTC-01
LH 65	LH65WS-01	LH65WSC-01	LH65PT-01	LH65PTC-01
LS 15	LS15WS-01	–	LS15PT-01	–
LS 20	LS20WS-01	LS20WSC-01	LS20PT-01	LS20PTC-01
LS 25	LS25WS-01	LS25WSC-01	LS25PT-01	LS25PTC-01
LS 30	LS30WS-01	LS30WSC-01	LS30PT-01	LS30PTC-01
LS 35	LS35WS-01	LS35WSC-01	LS35PT-01	LS35PTC-01
LW 17	LW17WS-01	–	LW17PT-01	–
LW 21	LW21WS-01	LW21WSC-01	LW21PT-01	LW21PTC-01
LW 27	LW27WS-01	LW27WSC-01	LW27PT-01	LW27PTC-01
LW 35	LW35WS-01	LW35WSC-01	LW35PT-01	LW35PTC-01
LW 50	LW50WS-01	LW50WSC-01	LW50PT-01	LW50PTC-01

* Grease extension connector

PU | Standard-Series

- › Miniature Linear Guides
- › Sizes 05, 07, 09, 12, 15
- › Preload: 0, 1, T
- › Stainless steel
- › Resin recirculation path
- › Light weight and smooth movement
- › Options: Slider with or without NSK K1® mounted

**Contact angle: 45°
DB configuration (0)**

Size	Maximum single rail length [mm]	Mounting bolt metric	Distance between mounting holes [mm]
05	210	M2	15
07	375	M2	15
09	600	M3	20
12	800	M3	25
15	1,000	M3	40

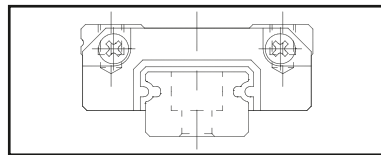
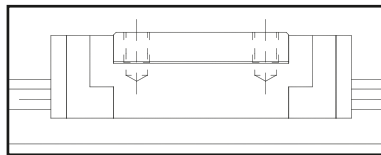

PE | Standard-Series

- › Miniature Wide Body Linear Guides
- › Sizes 05, 07, 09, 12, 15
- › Preload: 0, 1, T
- › Stainless steel
- › Resin recirculation path
- › Light weight and smooth movement
- › Options: Slider with or without NSK K1® mounted

**Contact angle: 45°
DB configuration (0)**

Size	Maximum single rail length [mm]	Mounting bolt metric	Distance between mounting holes [mm]
05	150	M2.5	20
07	600	M3	30
09	800	M3	30
12	1.000	M4	40
15	1.200	M4	40

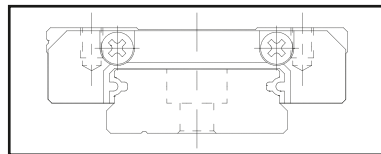
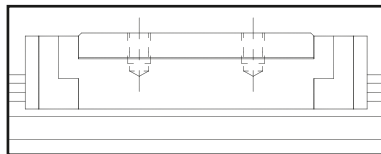

TS | Translide™ Standard-Series

- › Sizes 15, 20, 25, 30, 35
- › 1 type of slider: AN
- › Slight Clearance only
- › NSK K1® mounted as standard
- › Available in anti-corrosion Fluoride Raydent Plated treatment
- › Option: Mounting caps covering the drill holes or bottom mounting hole rails

Low cost (rolled rail)
High load capacity
High sealing capability
Interchangeable

Size	Maximum single rail length [mm]	Mounting bolt metric	Distance between mounting holes [mm]
15	1,960	M4	120
20	2,920	M5	120
25	4,000	M6	120
30	4,040	M8	160
35	4,040	M8	160

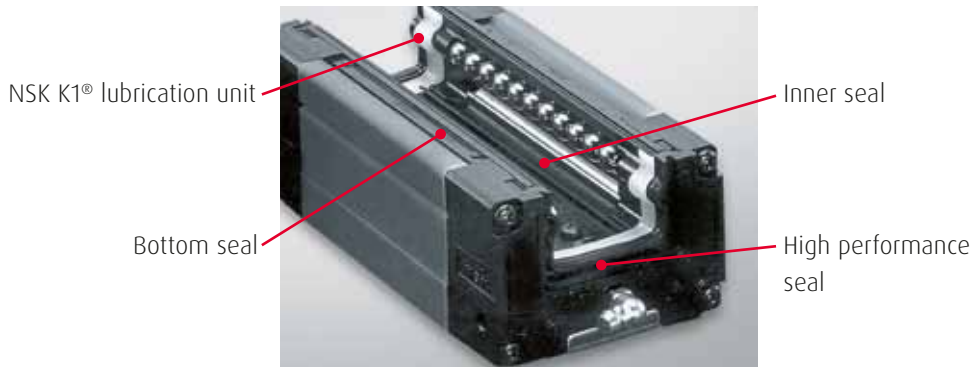

Rails without ball retainer groove to optimize sealing capability

RA | Linear Roller Guides | RA-Series

- › Sizes 15, 20, 25, 30, 35, 45, 55, 65
- › Slider types AN, AL, BN, BL, EM, GM
- › Only high preload H type
- › Options: slider with or without NSK K1® mounted, steel protector
- › Available in anticorrosion Fluoride Raydent Plated treatment
- › Option: Mounting caps covering the drill holes or bottom mounting hole rails

**Contact angle: 45°
DB configuration (0)**

Size	Maximum single rail length [mm]	Mounting bolt metric	Distance between mounting holes [mm]
15	2,000	M4	30.0
20	3,000	M5	30.0
25	3,000	M6	30.0
30	3,500	M6	40.0
35	3,500	M8	40.0
45	3,500	M12	52.5
55	3,500	M14	60.0
65	3,500	M16	75.0

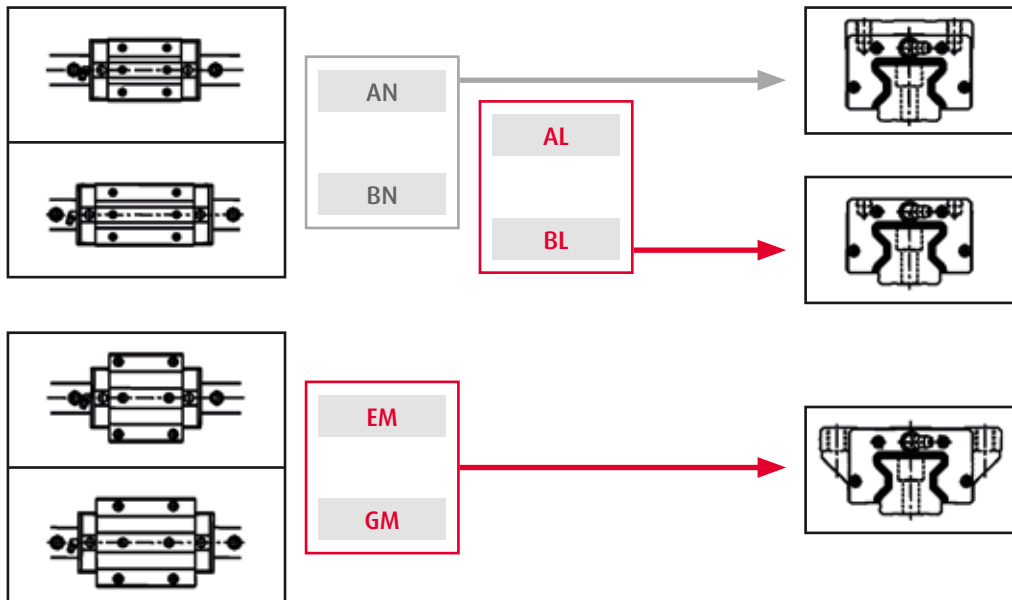

K1[®] Lubrication System

NSK K1[®] lubrication unit made up of 70% mineral oil and 30% porous resin.

- › Maintenance free system
- › Minimum waste of oil - No excess
- › Contact seal capability with low friction
- › Also available for special environments (like food, medical, etc.) FDA approved
- › Possible to assemble NSK K1[®] lubrication unit for high demanding applications

The porous resin contains a large amount of lubrication oil. NSK K1[®] lubrication units constantly supplies fresh oil which is released from the resin, lubricating the rail surface and all balls at point of contacts.



Test without Grease:

- › Slider: LAH30AN
- › Speed: 200m/min
- › Stroke: 1800mm

Running distance (Km)

NSK K1[®]

50,000

Without NSK K1[®]

79

NSK K1[®] system is available for all series and sizes of linear guides. Slider total length increases between 5 and 10mm per mounted piece.

Selection table for the number of K1[®] lubrication units per Slider

Type	Preload	External Load / Dynamic load rating			
LH, SH, LS, SS RA, LW	Z0, Z1	up to 8% C _a	up to 8% C _a	up to 11% C _a	up to 16% C _a
	Z3	up to 5% C _a	up to 8% C _a	up to 10% C _a	up to 15% C _a
LU, PU, PE	Z0, Z1	up to 5% C _a	up to 8% C _a	up to 8% C _a	up to 13% C _a
Required maintenance free life.	up to 3,000 km	2 pieces	4 pieces	4 pieces	Please request NSK
	up to 5,000 km			6 pieces	
	up to 10,000 km			4 pieces	
	up to 20,000 km				
	up to 50,000 km				
	over 50,000 km				

Linear Guides | Mounting tolerances

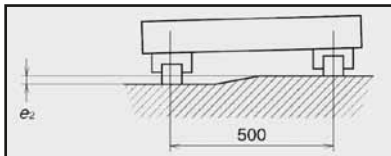
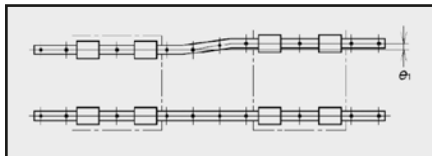

Tolerance	Preload	LH / SH								LS / SS					RA (Z3 only)							
		Size (μm)								Size (μm)					Size (μm)							
		15	20	25	30	35	45	55	65	15	20	25	30	35	15	20	25	30	35	45	55	65
e_1	Z_0, Z_T	22	30	40	45	55	65	80	110	20	22	30	35	40	-	-	-	-	-	-	-	-
	ZZ, Z_1	18	20	25	30	35	45	55	70	15	17	20	25	30	-	-	-	-	-	-	-	-
	Z_3	13	15	20	25	30	40	45	60	12	15	15	20	25	5	7	9	11	13	17	19	19
e_2	Z_0, Z_T	375 μm / 500 mm								375 μm / 500 mm					-							
	ZZ, Z_1, Z_3	335 μm / 500 mm								335 μm / 500 mm					150 μm / 500 mm							

Tolerance	Preload	PU					PE					LW				
		Size (μm)					Size (μm)					Size (μm)				
		5	7	9	12	15	5	7	9	12	15	17	21	27	35	50
e_1	Z_0, Z_T	10	12	15	20	25	10	12	15	18	22	20	20	25	38	50
	ZZ, Z_1	7	10	13	15	21	5	7	10	13	17	9	9	13	23	34
e_2	Z_0, Z_T	150 μm / 200 mm					50 μm / 200 mm					100 μm / 500 mm				
	ZZ, Z_1	90 μm / 500 mm					35 μm / 500 mm					45 μm / 500 mm				

Assembled (rail & slider) reference

LH 25 0960 AN C 2 * P6 T**

Serie types

- LH LH Series
- SH LH Series with S1
- LS LS Series
- SS LS Series with S1
- PU Miniature PU Series
- PE Wide Body Miniature PE Series
- LW Wide Body LW Series
- TS Translide Series
- RA Roller Series

Serie Sizes

- LH 08, 10, 12, 15, 20, 25, 30, 35, 45, 55, 65
- SH 15, 20, 25, 30, 35, 45, 55
- LS 15, 20, 25, 30, 35
- SS 15, 20, 25, 30, 35
- PU 05, 07, 09, 12, 15
- PE 05, 07, 09, 12, 15
- LW 17, 21, 27, 35, 50
- TS 15, 20, 25, 30, 30, 35
- RA 15, 20, 25, 30, 35, 45, 55, 65

Rail length (mm)

Longer lengths of 9,999:
F.e.:1,2580 mm = X126

Slider types

- Square type: AN, BN – normal height
- AL, BL, CL – Low Height
- AR, TR, UR – Miniature type
- Flange type: EL, EM, GM, JM

Preload

- T – no preload
- Z – slight preload
- H – high preload

Accuracy grades:

- PC, PN, P6, PH, P5, P4, P3
- Interchangeable: PC, PH, KC, KH
- With NSK K1®: KC, KN, K6, KH, K5, K4, K3

Design code

No. of sliders

1, 2, 3 ...

Material code

- C Standard carbon steel
- D C + Surface treatment
- H K + Surface treatment
- J V + K
- K Stainless steel
- P TS rail + C
- R TS rail + D
- V Bottom mounting holes
- W TS rail + D + V
- Z Special

Linear Guides | NSK reference system

Interchangeable slider reference

LA H 25 AN Z - K

Slider types:

LA All Series
SA With S1
PA PU/PE Series
TA TS Series
RA Roller Serie

Serie types

H LH / SH Series
S LS / SS / TS Series
U PU Series
E PE Series
W LW Series
A Roller Series

Sizes

LH 15, 20, 25, 30, 35, 45, 55, 65
SH 15, 20, 25, 30, 35, 45, 55
LS 15, 20, 25, 30, 35
SS 15, 20, 25, 30, 35
PU 05, 07, 09, 12, 15
PE 05, 07, 09, 12, 15
LW 17, 21, 27, 35, 50
TS 15, 20, 25, 30, 30, 35
RA 15, 20, 25, 30, 35, 45, 55, 65

NSK K1® lubrication unit

without NSK K1®
K with NSK K1®
F Surface treatment

Preload

T - no preload
Z - slight preload
H - high preload

Slider types

Square type: AN, BN - normal height
AL, BL, CL - Low Height
AR, TR, UR - Miniature type
Flange type: EL, EM, GM, JM

Interchangeable rail reference

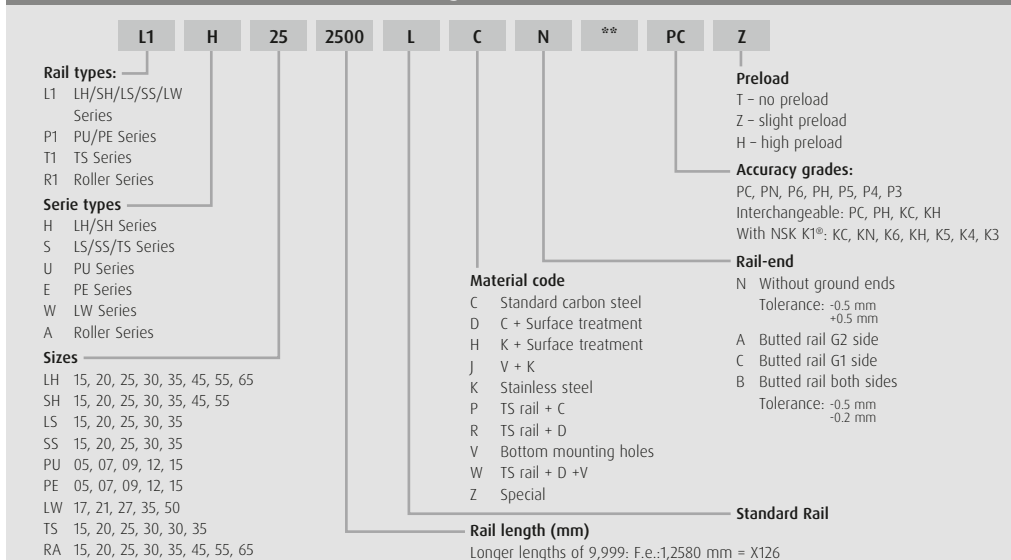

Monocarrier

- › Standard MCM Type
- › High rigidity MCH Type



MCM/MCH | Monocarrier | Compact single axis linear actuator

- › Sizes 02, 03, 05, 06, 08, 09, 10
- › Single or double slider
- › Standard type (MCM) or high rigidity type (MCH)
- › Options: Covers, sensors and motor brackets

	Size	Single slider max. stroke [mm]	Double slider max. stroke [mm]	Ball screw lead [mm]
MCM Type (Standard)	2	150	-	1 / 2
	3	250	-	1 / 2 / 10 / 12
	5	600	510	5 / 10 / 20
	6	800	710	5 / 10 / 20
	8	800	680	5 / 10 / 20
	10	1,000	87	10 / 20
MCH Type (high rigidity)	6	600	400	5 / 10 / 20
	L06	500	-	5 / 10 / 20
	9	800	650	5 / 10 / 20
	10	1,200	1,050	10 / 20

MCM/MCH | Monocarrier | Compact single axis linear actuator

MCM Type

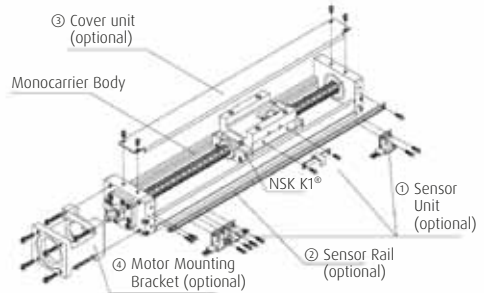

MCH Type

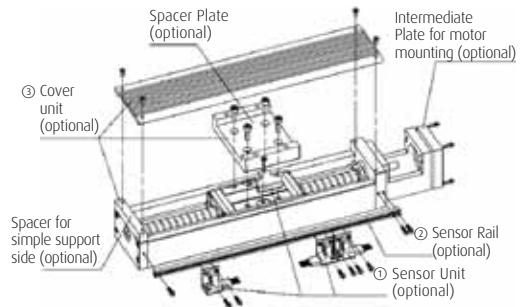

Monocarrier | NSK reference system

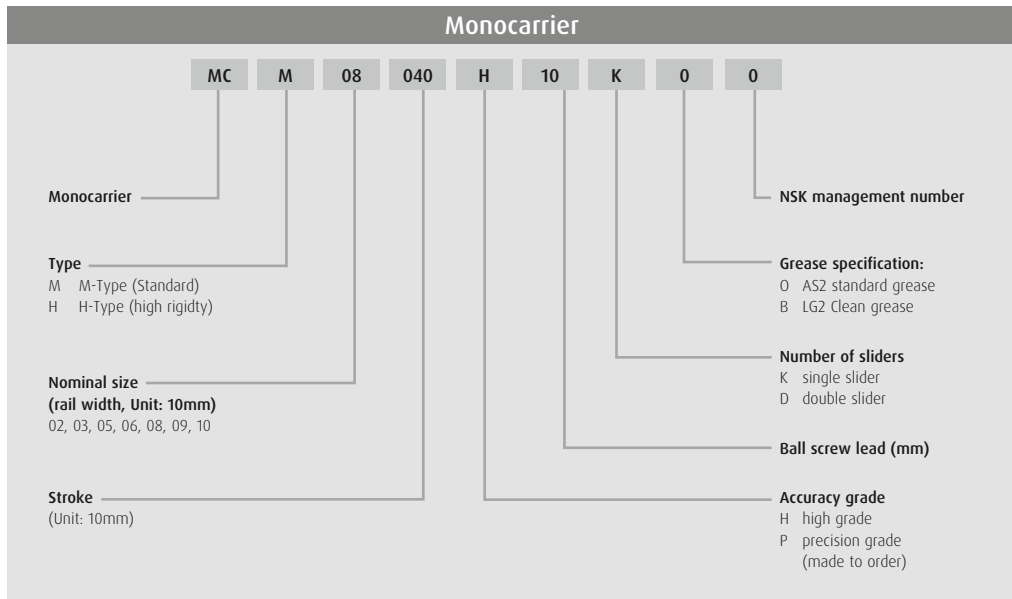







Ball Screws

- › R-BS – Rolled Ball Screw Series
- › CFA – Ground Ball Screw Compact FA Series
- › FSS – Ground Ball Screw FSS Series
- › DS – Ground Ball Screw DS Series
- › WBK – Support Units

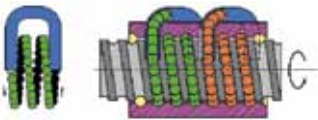

R-BS | Rolled Ball Screw Series

- › Low cost solution for non-high quality applications
- › Interchangeability between nuts and shafts of same diameter and leads
- › Multiple options for diameters and leads

Nut	RNFTL	RNFBL	RNCT	RNSTL	RNFCL
Design					
Recirculation	<p>Tube type</p> 				<p>End cap type</p> 
Assembly	Flange	Flange	V-thread	Direct mounting	Flange
Lead	Fine, medium, high	Fine and medium	Fine	Fine and medium	High and extra high

D	Lead (mm)															L _{max} (mm)
	3	4	5	6	8	10	12	16	20	25	32	40	50	64	80	
10	A C			A B												800
12					A B		A E									800
14		A B C D	A B C D													1,000
15									E							1,500
16						A		A E			E					1,500
18					A B C D											1,500
20			A B C D			A B D			A E		E					2,000
25			A B C D			A B C D				A E			E			2,500
28				A B C D												2,500
32						A B C D					A E			E (4000)		3,000
36						A B C D										3,000
40						A B C						A E			E (5000)	4,000
45																4,000
50						A C							E			4,000

A = RNFTL | B = RNFBL | C = RNCT | D = RNSTL | E = RNSTL

CFA | Ground Ball Screw Compact FA Series

- › Grounded Ball Screw Shaft
- › End Deflector Recirculation
- › Rotation speed up to 5,000 rpm
- › Low noise and smooth movement
- › No axial play
- › C5 Accuracy
- › Contact seal
- › Compactness
- › Fixed Machined shaft ends
- › New range support units available

Nut up to 30% more compact



System up to 13% lower

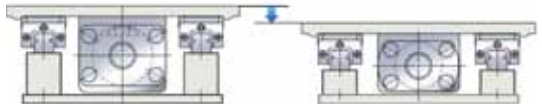

D (mm)	Lead (mm)	Stroke (mm)															
		50	100	150	200	300	400	500	600	700	800	1,000	1,200	1,600	2,000		
10	5	■	■	■	■	■	■	■	■	■	■	■	■	■	■	■	■
	10	■	■	■	■	■	■	■	■	■	■	■	■	■	■	■	■
12	5	■	■	■	■	■	■	■	■	■	■	■	■	■	■	■	■
	10	■	■	■	■	■	■	■	■	■	■	■	■	■	■	■	■
	20	■	■	■	■	■	■	■	■	■	■	■	■	■	■	■	■
	30	■	■	■	■	■	■	■	■	■	■	■	■	■	■	■	■
15	5	■	■	■	■	■	■	■	■	■	■	■	■	■	■	■	■
	10	■	■	■	■	■	■	■	■	■	■	■	■	■	■	■	■
	20	■	■	■	■	■	■	■	■	■	■	■	■	■	■	■	■
	30	■	■	■	■	■	■	■	■	■	■	■	■	■	■	■	■
20	5	■	■	■	■	■	■	■	■	■	■	■	■	■	■	■	■
	10	■	■	■	■	■	■	■	■	■	■	■	■	■	■	■	■
	20	■	■	■	■	■	■	■	■	■	■	■	■	■	■	■	■
	30	■	■	■	■	■	■	■	■	■	■	■	■	■	■	■	■
	40	■	■	■	■	■	■	■	■	■	■	■	■	■	■	■	■
	60	■	■	■	■	■	■	■	■	■	■	■	■	■	■	■	■
25	5	■	■	■	■	■	■	■	■	■	■	■	■	■	■	■	■
	10	■	■	■	■	■	■	■	■	■	■	■	■	■	■	■	■
	20	■	■	■	■	■	■	■	■	■	■	■	■	■	■	■	■
	25	■	■	■	■	■	■	■	■	■	■	■	■	■	■	■	■
	30	■	■	■	■	■	■	■	■	■	■	■	■	■	■	■	■
	50	■	■	■	■	■	■	■	■	■	■	■	■	■	■	■	■

FSS | Ground Ball Screw FSS Series

- › Ground Ball Screws
- › C_t7 grade accuracy
- › 24% more compact ball nut design
- › Higher speed till 125 m/min
- › 5 dB lower noise compared to existing series
- › The nut has up to 10 μm axial play.
- › Standard Stock Item
- › Fixed support at machined shaft end
- › Unfinished shaft end cut to a desired length
- › Simple support unit mounted at shaft outside surface

D (mm)	Lead (mm)	Stroke (mm)					
		400	500	600	900	1,000	1,450
12	10	■	□	■	■	□	□
15	10	□	■	□	□	■	□
	20	□	■	□	□	■	□
20	10	□	□	■	□	■	□
	20	□	□	■	□	■	□
25	10	□	□	■	□	■	□
	20	□	□	■	□	■	□
	25	□	□	■	□	■	□

For all sizes is the FSS Series in 8 variants available.



The simple support side unit, supports the ball screws outside diameter.

Cut the ball screw shaft end to the desired length and simply install a simple support unit on the shaft outside diameter, thus completing the ball screw assembly.

This makes ball screws available with the flexible stroke setting in combination with a fixed -simple support configuration to increase the critical speed



Screw shaft diameter	Fixed support side unit	Simple support side unit
12	WBK08-01B	WBK12SF-01B
15	WBK12-01B	WBK15SF-01B
20	WBK15-01B	WBK20SF-01B
25	WBK20-01	WBK25SF-01

DS | Ground Ball Screw DS Series

- › Ground Ball Screw
- › Compact nut design the DIN 69051-5
- › C5 accuracy grade
- › Preloaded ball nut, no axial play.
- › Compact ball nut design
- › 33 combinations in diameter, lead and length
- › Shaft ends are unmachined and non-hardened.
- › Standard stock item



D (mm)	Lead (mm)	Stroke (mm)							
		400	700	1,000	1,100	1,500	2,000	2,500	3,000
32	5	■	■	■		■			
	10	■	■	■		■	■		
	20			■		■	■		
40	5		■	■		■			
	10			■		■	■		
	20					■	■	■	■
50	10			■		■	■		
	20					■	■	■	■
63	10				■	■	■	■	

DS | Ground Ball Screw DS Series

NSK Reference number	Diameter d	Lead l	Nut Model Nr.	Basic load rating (N)		Preload (N) F _{a0}	Dynamic Preload Torque T _p (N-cm)
				dyn. C _a	stat. C _{0a}		
W3204DS-4PSS-C5Z5	32	5	BSS3205-5E	21,900	52,900	530	3.5-15.6
W3207DS-2PSS-C5Z5							2.5-17.6
W3210DS-2PSS-C5Z5							2.5-17.6
W3215DS-1PSS-C5Z5							2.0-21.5
W3204DS-3PY-C5Z10	32	10	PFD3210-5	35,600	69,700	855	13.8-33.5
W3207DS-4PY-C5Z10							11.8-35.5
W3210DS-5PY-C5Z10							11.8-35.5
W3215DS-4PY-C5Z10							9.3-37.5
W3220DS-3PY-C5Z10							9.3-37.5
W3210DS-4PSS-C5Z20	32	20	PR3220-4	23,800	51,500	570	10.8-32.5
W3215DS-3PSS-C5Z20							8.8-36.5
W3220DS-2PSS-C5Z20							8.8-36.5
W4007DS-2PY-C5Z5	40	5	PFD4005-6	28,000	78,400	680	6.4-20.5
W4010DS-2PY-C5Z5							4.7-22.5
W4015DS-1PY-C5Z5							4.7-22.5
W4010DS-4PY-C5Z10	40	10	PFD4010-6	68,000	14,000	1.630	28.5-66.0
W4015DS-4PY-C5Z10							28.5-66.0
W4020DS-3PY-C5Z10							25.5-69.0

Note: All rated capacities are based on valid DIN and ISO formulas.

	Nut Dimensions							Screw shaft Dimensions		
	Outer Diameter	Flange			Length	Bolt Holes		Thread	Overall Length	
	D	A	G	B	Ln	W	X	Lt	L0	L1
50	80	62	12	46	65	9	400	600	200	
							700	900	200	
							1,000	1,250	250	
							1,500	1,800	300	
50	80	62	12	102	65	9	400	600	200	
							700	900	200	
							1,000	1,250	250	
							1,500	1,800	300	
							2,000	2,300	300	
50	80	62	12	98	65	9	1,000	1,250	250	
							1,500	1,800	300	
							2,000	2,300	300	
63	93	70	14	64	78	9	700	1,000	300	
							1,000	1,300	300	
							1,500	1,800	300	
63	93	70	18	123	78	9	1,000	1,300	300	
							1,500	1,800	300	
							2,000	2,300	300	

DS | Ground Ball Screw DS Series

NSK Reference Number	Diameter d	Lead l	Nut Model Nr.	Basic load rating (N)		Preload (N) F _{a0}	Dynamic Preload Torque T _p (N-cm)
				dyn. C _a	stat. C _{0a}		
W4015DS-3PY-C5Z20	40	20	PFD4020-4	48,000	93,300	1,150	28.5-66.0
W4020DS-2PY-C5Z20							25.5-69.0
W4025DS-1PY-C5Z20							25.5-69.0
W4030DS-1PY-C5Z20							25.5-69.0
W5010DS-2PY-C5Z10	50	10	PFD5010-6	77,300	183,000	1,850	23.5-51.0
W5015DS-2PY-C5Z10							21.5-53.0
W5020DS-2PY-C5Z10							21.5-53.0
W5015DS-3PY-C5Z20							41.0-86.0
W5020DS-3PY-C5Z20	50	20	PFD5020-3	56,000	109,000	1,340	41.0-86.0
W5025DS-1PY-C5Z20							37.5-91.0
W5030DS-1PY-C5Z20							37.5-91.0
W6311DS-1PY-C5Z10							55.0-102.0
W6315DS-1PY-C5Z10	63	10	PFD6310-6	88,100	244,000	2,120	51.0-106.0
W6320DS-1PY-C5Z10							51.0-106.0
W6325DS-1PY-C5Z10							51.0-106.0

Note: All rated capacities are based on valid DIN and ISO formulas.

	Nut Dimensions							Screw shaft Dimensions		
	Outer Diameter	Flange			Length	Bolt Holes		Thread	Overall Length	
	D	A	G	B	Ln	W	X	Lt	L0	L1
63	93	70	18	138	78	9	1,500	1,800	300	
							2,000	2,300	300	
							2,500	2,800	300	
							3,000	3,350	350	
75	110	85	18	114	93	11	1,000	1,300	300	
							1,500	1,800	300	
							2,000	2,300	300	
							1,500	1,800	300	
75	110	85	18	133	93	11	2,000	2,300	300	
							2,500	2,900	400	
							3,000	3,400	400	
							1,100	1,300	200	
90	125	95	22	118	108	11	1,500	1,900	400	
							2,000	2,400	400	
							2,500	2,900	400	
							2,500	2,900	400	

Ball Screws | NSK reference system

Rolled ball screw reference

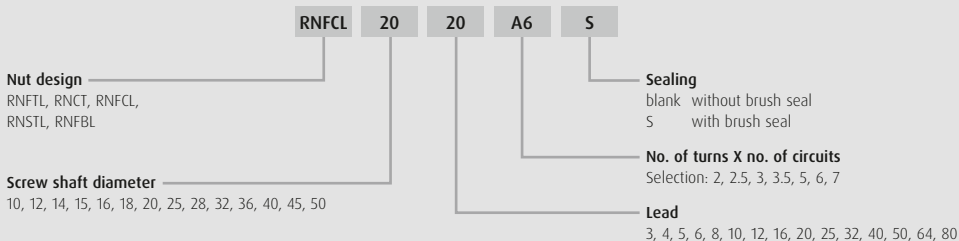
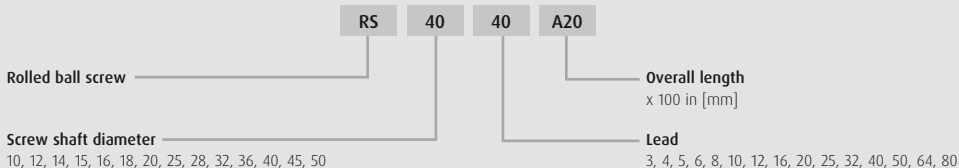

Compact FA & FSS reference

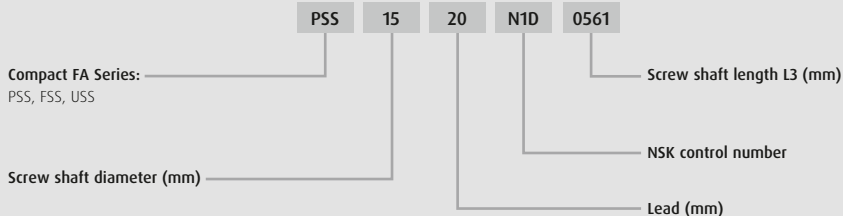

















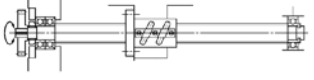

PSS: Compact, low noise and high speed

FSS: Compact FA for transportation

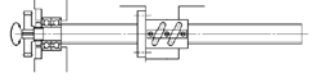
USS: High accuracy compact FA

WBK | Support Units

- › High dust prevention
- › Low friction torque

Supporting Method	Application	Rigidity	Critical Speed	Buckling Load	Length	Economical	Easy Installation
Fixed - Fixed							
Fixed - Simple							
Fixed - Free							

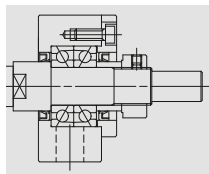

WBK**-01

- › Fixed support side
(Driving motor side)
- › Square
- › $\varnothing 6 - \varnothing 25$

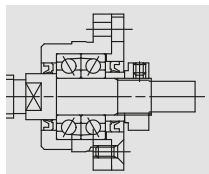

WBK**-11

- › Fixed support side
(Driving motor side)
- › Flange
- › $\varnothing 6 - \varnothing 25$

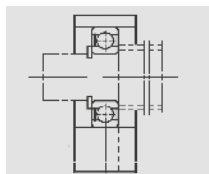

WBK**-S-01

- › Simple support side
(Opposite to drive motor)
- › Square
- › $\varnothing 6 - \varnothing 25$

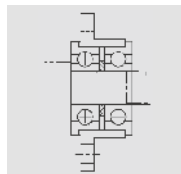

WBK**-R-01

- › Fixed support side
(Driving motor side)
- › Flange
- › $\varnothing 4 - \varnothing 6$

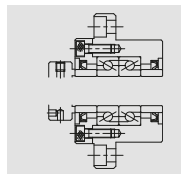

WBK**-DF*-31

- › Fixed support side
(Driving motor side)
- › $\varnothing 36 - \varnothing 50$

DF combination

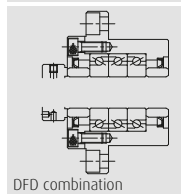

DFD combination

Support Units | NSK reference system

For heavy load

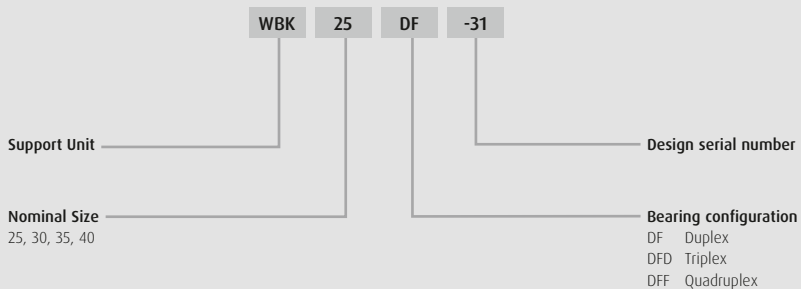

For light load

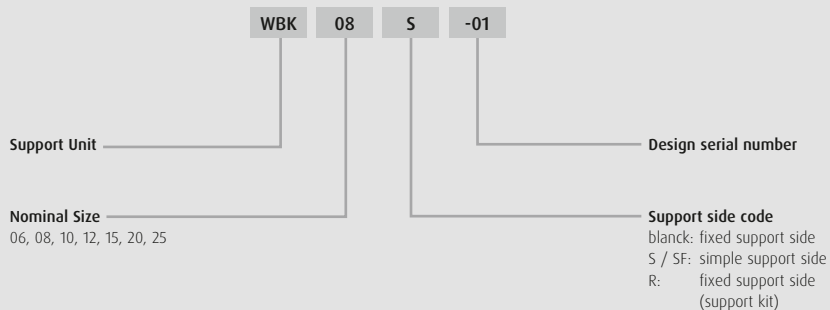

Megatorque Motors

- › PS-Series
- › PN-Series



Megatorque Motors | Comparison features PS/PN Series

PS Series

- › Outer rotor
- › Small diameter
- › Fixed from the bottom
- › High rotational speed
- › Small installation space
- › Compact, clean, high accuracy, hollow structure, maintenance free
- › For high-speed positioning of medium/light loads

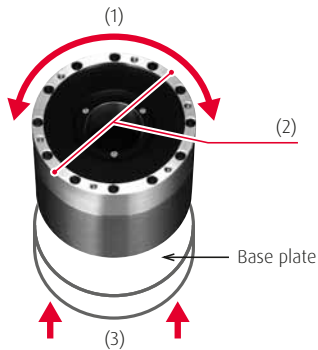

- (1) Outer rotor
- (2) Small diameter
- (3) Fixed from the bottom

PN Series

- › Inner rotor
- › Low profile
- › Fixed from the top
- › High rigidity
- › Low motor height
- › Compact, clean, high accuracy, hollow structure, maintenance free
- › For positioning of large loads

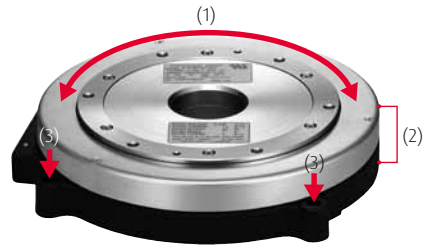

- (1) Inner rotor
- (2) Low profile
- (3) Fixed from the top

Megatorque Motors | PS/PN Series

Conventional system

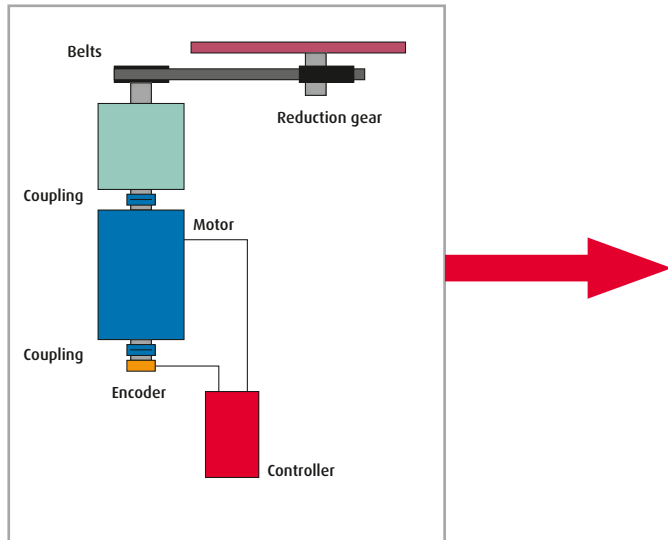

Megatorque motor

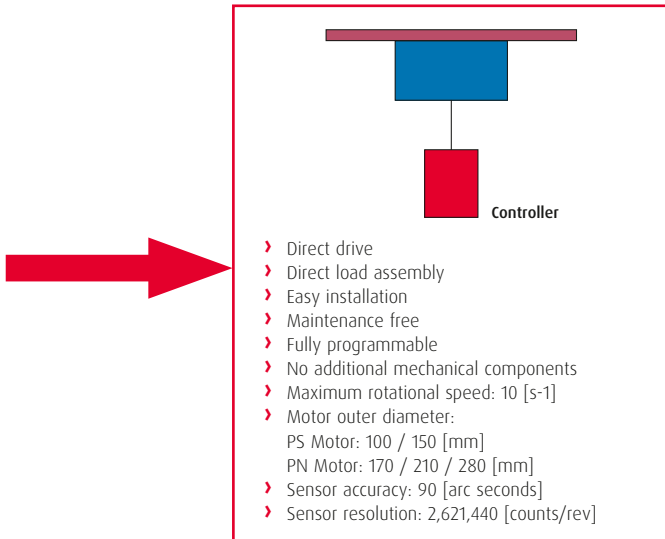

Megatorque Motors | PS Series

System configuration

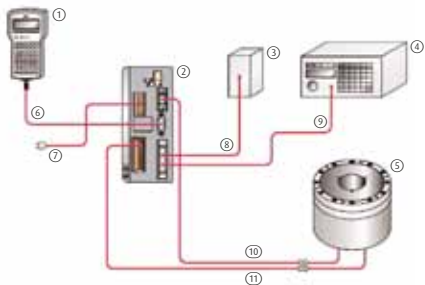

- ① Handy Terminal FHT21*
 - ② EDC Driver Unit*
 - ③ 24[VDC] power supply
 - ④ Programmable controller (PLC)/Pulse train controller
 - ⑤ Megatorque-Motor PS-Series*
 - ⑥ RS-232C communication
 - ⑦ Main power and Control power
(Single-phase 200–230 [VAC], Single-phase 100–120 [VAC])
 - ⑧ External power supply for I/O signals
 - ⑨ Control I/O signals
 - ⑩ Cable set* Resolver cable
 - ⑪ Motor cable*
- *NSK Product

	PS 1			PS 3			
Maximum output torque [Nm]	6	12	18	15	30	60	90
Motor height [mm]	85	110	135	85	102	136	170
Motor outer diameter [mm]	D = 100			D = 150			
Motor hollow diameter [mm]	D = 35			D = 56			
Mass [kg]	2.4	3.5	4.5	5.5	6.9	11.0	13.8
Allowable axial load [N]	1000 (under no radial load)			2000 (under no radial load)			
Applied load inertia moment [kg·m ²]	0.015–0.240	0.030–0.310	0.030–0.380	0–1.100	0–1.400	0.120–1.900	0.120–2.400

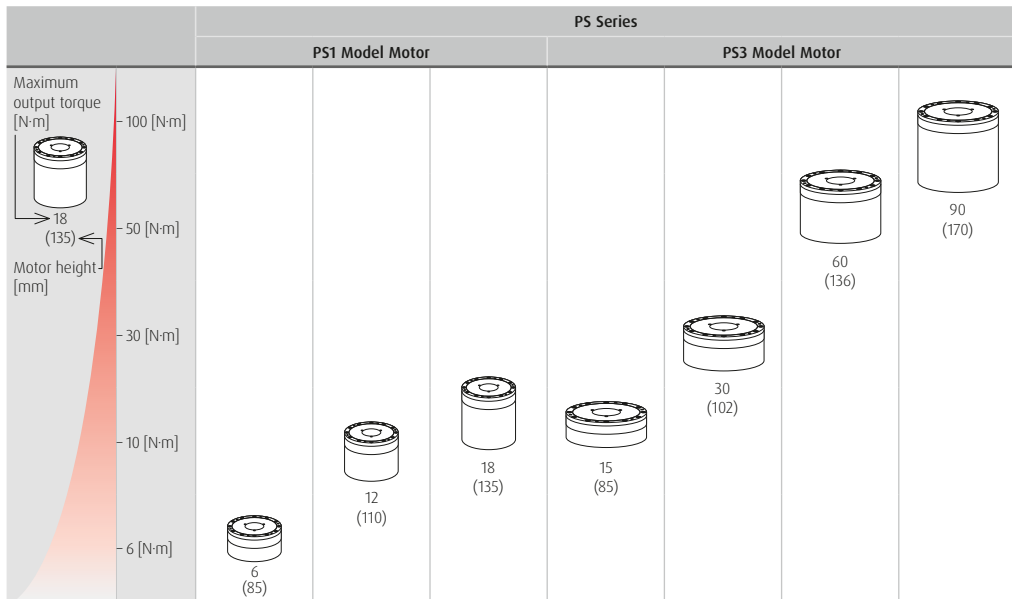

Megatorque Motors | PS Series

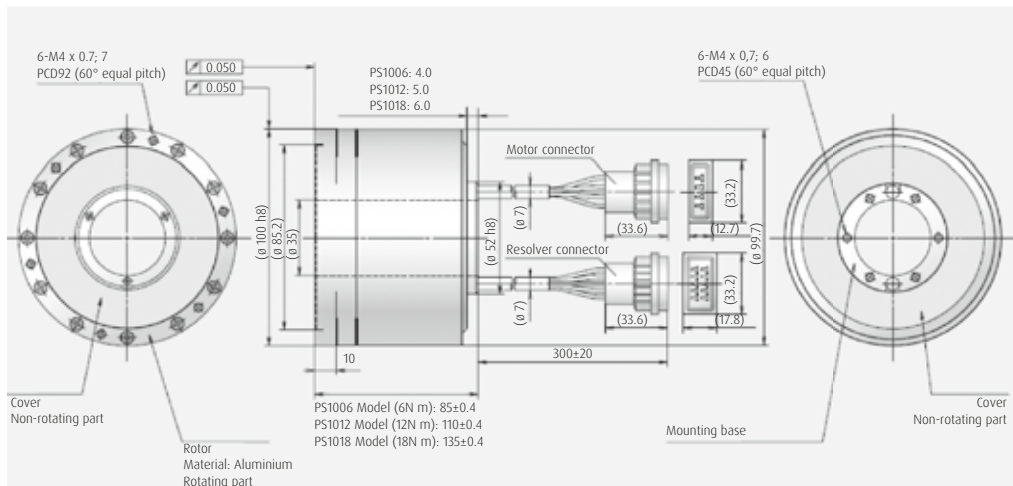

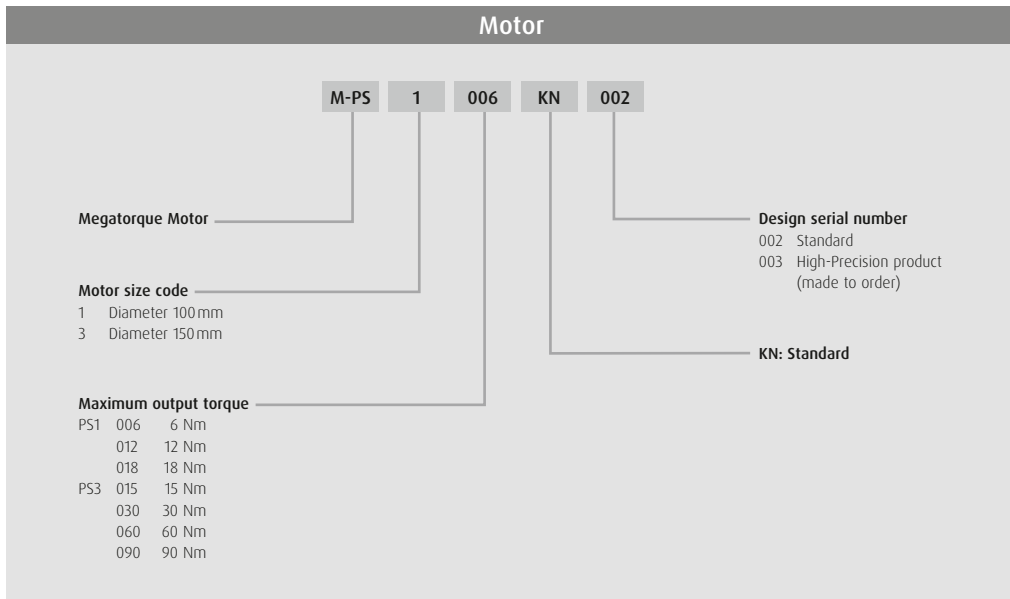

Megatorque Motor | Reference System | PS Series

Controller

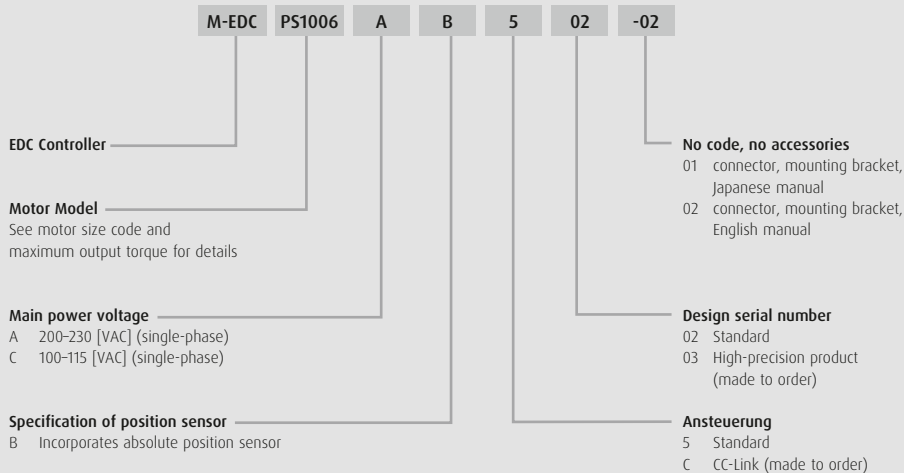

Rear mounting hole

Mounting bracket available as accessory for front mounting.

Independent inputs of main power and control power

Separate power lines assure system safety.

Motor cable connector

Clamping type connector shortens work time and prevents mis-wiring.



7-segment LED indicators

Driver Unit status can be confirmed at a glance.

Analog monitor output terminal

Speed, positioning error, torque, motor current, etc. can be monitored by analog voltage. Effectively used for set up tuning or for monitoring operating status.

RS-232C communication connector

Connect the handy terminal to set parameters. Use the EDC Megaterm software to communicate with a PC.

Control signal I/O connector

A variety of signals are available, including servo on, in-position, emergency stop, area signal, override, various alarm outputs, A/ ϕ B/ ϕ Z, etc.

Megatorque Motors | PN Series

	PN 2012	PN 3045	PN 4135	PN 4180
Maximum output torque [N·m]	12	45	135	180
Motor height [mm]	35	85	95	112
Motor outer diameter [mm]	D = 170	D = 210	D = 280	
Motor hollow diameter [mm]	D = 36	D = 56	D = 50	
Mass [kg]	3.7	13	26	31
Allowable axial load [N]	1.000 (under no radial load)	4.500 (under no radial load)	9.500 (under no radial load)	
Rotor's moment of inertia [kg·m ²]	0.02-0.24	0.11-0.77	0.57-3.99	0.65-4.55



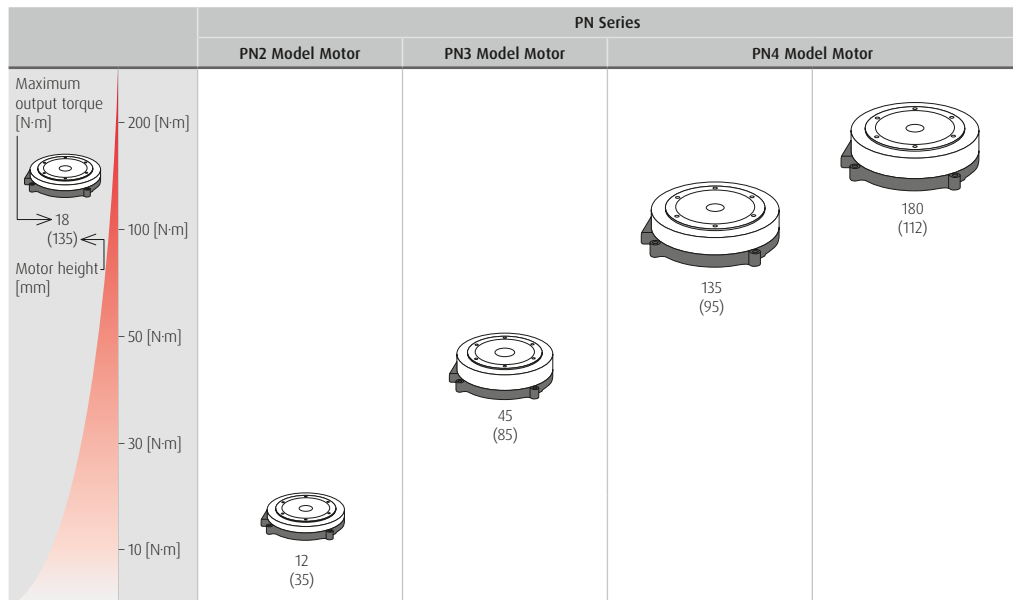

Megatorque Motors | PN Series

Rear mounting hole

Mounting bracket available as accessory for front mounting.

Independent inputs of main power and control power

Separate power lines assure system safety.

Motor cable connector

Clamping type connector shortens work time and prevents mis-wiring.



7-segment LED indicators

Driver Unit status can be confirmed at a glance.

Analog monitor output terminal

Speed, positioning error, torque, motor current, etc. can be monitored by analog voltage. Effectively used for set up tuning or for monitoring operating status.

RS-232C communication connector

Connect the handy terminal to set parameters. Use the EDC Megaterm software to communicate with a PC.

Control signal I/O connector

A variety of signals are available, including servo on, in-position, emergency stop, area signal, override, various alarm outputs, $\phi A/\phi B/\phi Z$, etc.

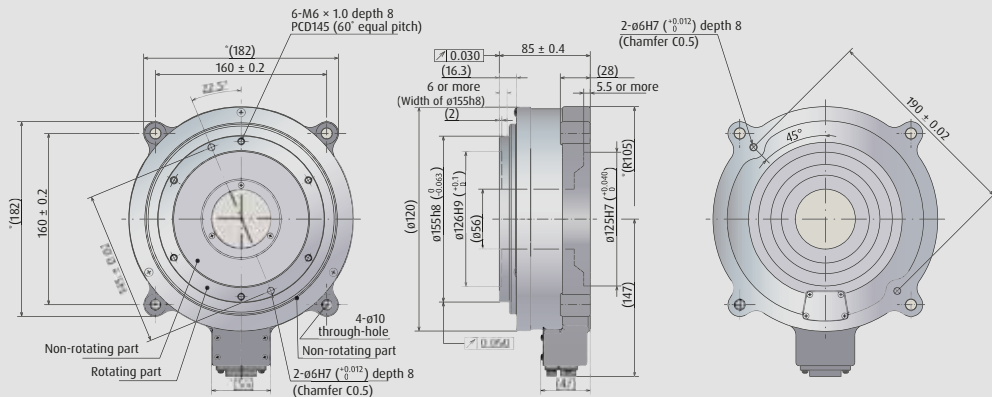

Dimensions marked with * indicate casting surfaces. Allow for more than 3 [mm] to the casting surface.

When inserting a pin into the output shaft pinhole [2-ø6H7 depth 8]:

- ▶ Set tolerance of the inserting pin for clearance fit.
- ▶ Do not apply excessive load and/or impact to the motor when inserting the pin.
- ▶ Use the pinhole for positioning only, not for supporting a load.

Megatorque Motor | Reference System | PN Series

Motor

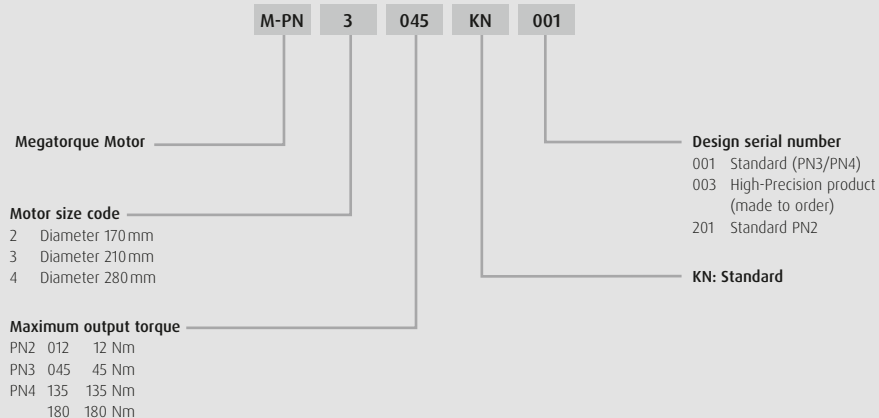

Controller

M-EDC PN3045 A B 5 02 -01

EDC Controller

Motor Model

See motor size code and maximum output torque for details

Main power voltage

- A 200-230 [VAC] (single-phase)
- C 100-115 [VAC] (single-phase)

Specification of position sensor

- B Incorporates absolute position sensor

No code, no accessories

- 01 connector, mounting bracket, Japanese manual
- 02 connector, mounting bracket, English manual

Design serial number

- 02 Standard
- 03 High-precision product (made to order)

Function

- 5 Standard
- C CC-Link (made to order)

Megatorque Motor | Reference System | PS/PN Series

Cable

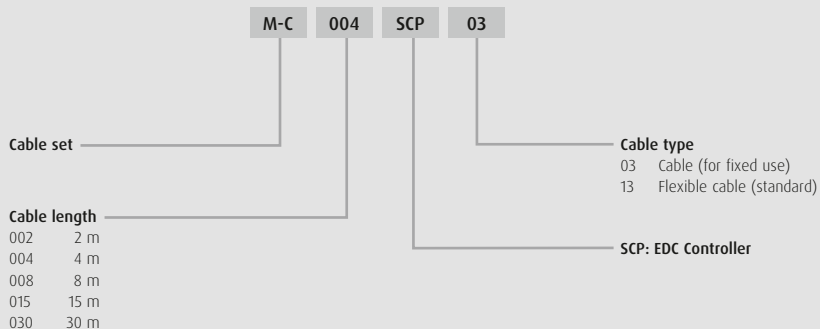

Connector

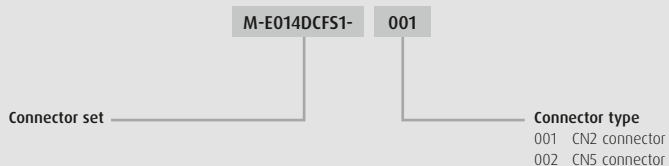

Handy terminal

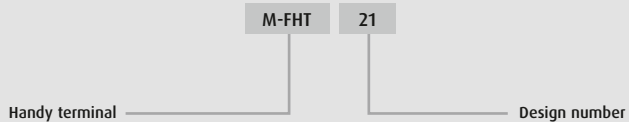

Solid Components | CAD-Data at Internet

The screenshot shows the NSK Solid Components website. The interface includes a search bar on the left, a main content area with technical drawings and a table, and a navigation menu at the top. Red lines with dots point from text labels to specific features on the page.

Multi language Catalogues

Search engine

Calculation software

Product information, including dimensions and load capacities

Part No.	Type	Material	Weight	Lead Time	Price	Stock	Order Qty	Min. Order Qty	Max. Order Qty
NSK1000-01	Ball screw for NSK	SK	1.0	10	1000	10	10	10	10
NSK1000-02	Ball screw for NSK	SK	1.0	10	1000	10	10	10	10
NSK1000-03	Ball screw for NSK	SK	1.0	10	1000	10	10	10	10
NSK1000-04	Ball screw for NSK	SK	1.0	10	1000	10	10	10	10
NSK1000-05	Ball screw for NSK	SK	1.0	10	1000	10	10	10	10
NSK1000-06	Ball screw for NSK	SK	1.0	10	1000	10	10	10	10
NSK1000-07	Ball screw for NSK	SK	1.0	10	1000	10	10	10	10
NSK1000-08	Ball screw for NSK	SK	1.0	10	1000	10	10	10	10
NSK1000-09	Ball screw for NSK	SK	1.0	10	1000	10	10	10	10
NSK1000-10	Ball screw for NSK	SK	1.0	10	1000	10	10	10	10

www.nsk.solidcomponents.com

European NSK Sales Offices

UK

NSK UK Ltd.
Northern Road, Newark
Nottinghamshire NG24 2JF
Tel. +44 (0) 1636 605123
Fax +44 (0) 1636 643276
info-uk@nsk.com

France

NSK France S.A.S.
Quartier de l'Europe
2, rue Georges Guynemer
78283 Guyancourt Cedex
Tel. +33 (0) 1 30573939
Fax +33 (0) 1 30570001
info-fr@nsk.com

Germany

NSK Deutschland GmbH
Harkortstraße 15
40880 Ratingen
Tel. +49 (0) 2102 4810
Fax +49 (0) 2102 4812290
info-de@nsk.com

Italy

NSK Italia S.p.A.
Via Garibaldi, 215
20024 Garbagnate
Milanese (MI)
Tel. +39 02 995 191
Fax +39 02 990 25 778
info-it@nsk.com

Norway

Nordic Sales Office

NSK Europe Norwegian Branch NUF
Østre Kullerød 5
N-3241 Sandefjord
Tel. +47 33 293160
Fax +47 33 429002
info-n@nsk.com

Poland & CEE

NSK Polska Sp. z o.o.
Warsaw Branch
Ul. Migdałowa 4/73
02-796 Warszawa
Tel. +48 22 645 15 25
Fax +48 22 645 15 29
info-pl@nsk.com

South Africa

NSK South Africa (Pty) Ltd.
27 Galaxy Avenue
Linbro Business Park
Sandton 2146
Tel. +27 (011) 458 3600
Fax +27 (011) 458 3608
nsk-sa@nsk.com

Spain

NSK Spain, S.A.
C/ Tarragona, 161 Cuerpo Bajo
2ª Planta, 08014 Barcelona
Tel. +34 93 2892763
Fax +34 93 4335776
info-es@nsk.com

Sweden

NSK Sweden Office
Karolinen Företagscenter
Våxnäsgratan 10
SE-65340 Karlstad
Tel. +46 5410 3545
Fax +46 5410 3544
info-de@nsk.com

Turkey

NSK Rulmanları Orta Doğu Tic. Ltd. Şti
19 Mayıs Mah. Atatürk Cad.
Ulya Engin İş Merkezi No: 68/3 Kat. 6
P.K.: 34736 - Kozyatağı - İstanbul
Tel. +90 216 4777111
Fax +90 216 4777174
turkey@nsk.com

Please also visit our website: www.nskeurope.com
Global NSK: www.nsk.com
CAD-Data: www.nsk.solidcomponents.com

MOTION & CONTROL™
NSK

Every care has been taken to ensure the information in this publication is accurate but no liability can be accepted for any errors or omissions. © Copyright NSK 2010. The contents of this publication are the copyright of the publishers. Printed in Germany. Ref: LIN/C/E/04.12

